

ESP-WROOM-32 Datasheet



Espressif Systems

April 14, 2017

About This Guide

This document provides introduction to the specifications of the ESP-WROOM-32 module.

The document structure is as follows:

Chapter	Title	Subject
Chapter 1	Preface	An overview of ESP-WROOM-32
Chapter 2	Pin Definitions	Device pinout and pin descriptions
Chapter 3	Functional Description	Description of major functional modules and protocols
Chapter 4	Electrical Characteristics	Electrical characteristics and specifications of ESP-WROOM-32
Chapter 5	Schematics	The schematics of ESP-WROOM-32
Chapter 6	Learning Resources	ESP32-related must-read materials and must-have resources

Release Notes

Date	Version	Release notes
2016.08	V1.0	First release.
2016.11	V1.1	Updated Chapter 5 Schematics.
2016.11	V1.2	Added Figure 2 Peripheral Schematics.
2016.12	V1.3	Updated Section 2.1 Pin Layout.
2017.03	V1.4	Updated Chapter 1 Preface; Updated Chapter 2 Pin Definitions; Updated Chapter 3 Functional Description; Updated Table 8 Recommended Operating Conditions; Updated Table 10 Wi-Fi Radio Characteristics; Updated Section 4.6 Reflow Profile; Added Chapter 6 Learning Resources.
2017.03	V1.5	Updated Section 2.2 Pin Description; Updated Section 3.2 External Flash and SRAM; Updated Section 3.5.1 Peripherals and Sensors Description.
2017.04	V1.6	Added Figure 3 Reflow Profile.

Disclaimer and Copyright Notice

Information in this document, including URL references, is subject to change without notice. THIS DOCUMENT IS PROVIDED AS IS WITH NO WARRANTIES WHATSOEVER, INCLUDING ANY WARRANTY OF MERCHANTABILITY, NON-INFRINGEMENT, FITNESS FOR ANY PARTICULAR PURPOSE, OR ANY WARRANTY OTHERWISE ARISING OUT OF ANY PROPOSAL, SPECIFICATION OR SAMPLE.

All liability, including liability for infringement of any proprietary rights, relating to use of information in this document is disclaimed. No licenses express or implied, by estoppel or otherwise, to any intellectual property rights are granted herein. The Wi-Fi Alliance Member logo is a trademark of the Wi-Fi Alliance. The Bluetooth logo is a registered trademark of Bluetooth SIG.

All trade names, trademarks and registered trademarks mentioned in this document are property of their respective owners, and are hereby acknowledged.

Copyright © 2017 Espressif Inc. All rights reserved.

Contents

1 Preface	1
2 Pin Definitions	3
2.1 Pin Layout	3
2.2 Pin Description	4
2.3 Strapping Pins	5
3 Functional Description	7
3.1 CPU and Internal Memory	7
3.2 External Flash and SRAM	7
3.3 Crystal Oscillators	7
3.4 Power Consumption	8
3.5 Peripherals and Sensors	9
3.5.1 Peripherals and Sensors Description	9
3.5.2 Peripheral Schematics	14
4 Electrical Characteristics	15
4.1 Absolute Maximum Ratings	15
4.2 Recommended Operating Conditions	15
4.3 Digital Terminal Characteristics	15
4.4 Wi-Fi Radio	15
4.5 Bluetooth LE Radio	16
4.5.1 Receiver	16
4.5.2 Transmit	16
4.6 Reflow Profile	17
5 Schematics	18
6 Learning Resources	19
6.1 Must-Read Documents	19
6.2 Must-Have Resources	19

List of Tables

1	ESP-WROOM-32 Specifications	1
2	ESP-WROOM-32 Dimensions	3
3	ESP-WROOM-32 Pin Definitions	4
4	Strapping Pins	5
5	Power Consumption by Power Modes	8
6	Peripherals and Sensors Description	9
7	Absolute Maximum Ratings	15
8	Recommended Operating Conditions	15
9	Digital Terminal Characteristics	15
10	Wi-Fi Radio Characteristics	15
11	Receiver Characteristics - BLE	16
12	Transmit Characteristics - BLE	16

List of Figures

1	Top and Side View of ESP-WROOM-32	3
2	ESP-WROOM-32 Peripheral Schematics	14
3	Reflow Profile	17
4	ESP-WROOM-32 Schematics	18

1. Preface

ESP-WROOM-32 is a powerful, generic Wi-Fi+BT+BLE MCU module that targets a wide variety of applications, ranging from low-power sensor networks to the most demanding tasks, such as voice encoding, music streaming and MP3 decoding.

At the core of this module is the ESP32-D0WDQ6 chip*, which is designed to be scalable and adaptive. There are two CPU cores that can be individually controlled or powered, and the clock frequency is adjustable from 80 MHz to 240 MHz. The user may also power off the CPU and make use of the low-power coprocessor to constantly monitor the peripherals for changes or crossing of thresholds. ESP32 integrates a rich set of peripherals, ranging from capacitive touch sensors, Hall sensors, low-noise sense amplifiers, SD card interface, Ethernet, high speed SDIO/SPI, UART, I2S and I2C.

Note:

* For details on the part number of the ESP32 series, please refer to the document [ESP32 Datasheet](#).

The integration of Bluetooth, Bluetooth LE and Wi-Fi ensures that a wide range of applications can be targeted, and that the module is future proof: using Wi-Fi allows a large physical range and direct connection to the internet through a Wi-Fi router, while using Bluetooth allows the user to conveniently connect to the phone or broadcast low energy beacons for its detection. The sleep current of the ESP32 chip is less than 5 μ A, making it suitable for battery powered and wearable electronics applications. ESP-WROOM-32 supports data rates of up to 150 Mbps, and 22 dBm output power at the PA to ensure the widest physical range. As such the chip does offer industry-leading specifications and the best performance for electronic integration, range, power consumption, and connectivity.

The operating system chosen for ESP32 is freeRTOS with LwIP; TLS 1.2 with hardware acceleration is built in as well. Secure (encrypted) over the air (OTA) upgrade is also supported, so that developers can continually upgrade their products even after their release.

Table 1 provides the specifications of ESP-WROOM-32.

Table 1: ESP-WROOM-32 Specifications

Categories	Items	Specifications
Wi-Fi	Standards	FCC/CE/IC/TELEC/KCC/SRRC/NCC
	Protocols	802.11 b/g/n/e/i (802.11n up to 150 Mbps) A-MPDU and A-MSDU aggregation and 0.4 μ s guard interval support
	Frequency range	2.4 ~ 2.5 GHz
Bluetooth	Protocols	Bluetooth v4.2 BR/EDR and BLE specification
	Radio	NZIF receiver with -98 dBm sensitivity
		Class-1, class-2 and class-3 transmitter
		AFH
Audio	CVSD and SBC	

Categories	Items	Specifications
Hardware	Module interface	SD card, UART, SPI, SDIO, I2C, LED PWM, Motor PWM, I2S, I2C, IR
		GPIO, capacitive touch sensor, ADC, DAC, LNA pre-amplifier
	On-chip sensor	Hall sensor, temperature sensor
	On-board clock	40 MHz crystal
	Operating voltage	2.2 ~ 3.6V
	Operating current	Average: 80 mA
	Operating temperature range	-40°C ~ 85°C
	Ambient temperature range	Normal temperature
Package size	18 mm x 25.5 mm x 2.8 mm	
Software	Wi-Fi mode	Station/SoftAP/SoftAP+Station/P2P
	Security	WPA/WPA2/WPA2-Enterprise/WPS
	Encryption	AES/RSA/ECC/SHA
	Firmware upgrade	UART Download / OTA (via network) / download and write firmware via host
	Software development	Supports Cloud Server Development / SDK for custom firmware development
	Network protocols	IPv4, IPv6, SSL, TCP/UDP/HTTP/FTP/MQTT
	User configuration	AT instruction set, cloud server, Android/iOS app

2. Pin Definitions

2.1 Pin Layout

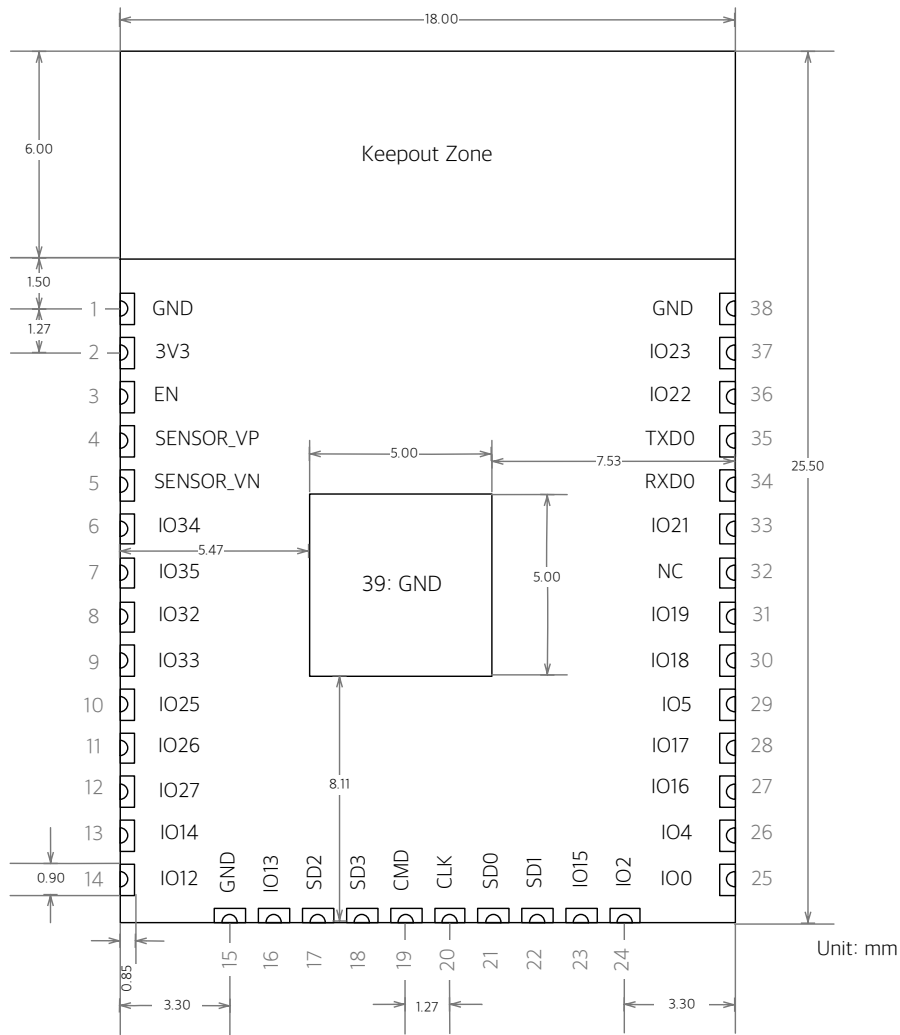

Figure 1: Top and Side View of ESP-WROOM-32

Table 2: ESP-WROOM-32 Dimensions

Length	Width	Height	PAD size (bottom)	Pin pitch	Shielding can height	PCB thickness
18 mm	25.5 mm	2.8 ± 0.1 mm	0.85 mm x 0.9 mm	1.27 mm	2 mm	0.8 ± 0.1 mm

2.2 Pin Description

ESP-WROOM-32 has 39 pins. See pin definitions in Table 3.

Table 3: ESP-WROOM-32 Pin Definitions

Name	No.	Type	Function
GND	1	P	Ground
3V3	2	P	Power supply.
EN	3	I	Chip-enable signal. Active high.
SENSOR_VP	4	I	GPIO36, SENSOR_VP, ADC_H, ADC1_CH0, RTC_GPIO0
SENSOR_VN	5	I	GPIO39, SENSOR_VN, ADC1_CH3, ADC_H, RTC_GPIO3
IO34	6	I	GPIO34, ADC1_CH6, RTC_GPIO4
IO35	7	I	GPIO35, ADC1_CH7, RTC_GPIO5
IO32	8	I/O	GPIO32, XTAL_32K_P (32.768 kHz crystal oscillator input), ADC1_CH4, TOUCH9, RTC_GPIO9
IO33	9	I/O	GPIO33, XTAL_32K_N (32.768 kHz crystal oscillator output), ADC1_CH5, TOUCH8, RTC_GPIO8
IO25	10	I/O	GPIO25, DAC_1, ADC2_CH8, RTC_GPIO6, EMAC_RXD0
IO26	11	I/O	GPIO26, DAC_2, ADC2_CH9, RTC_GPIO7, EMAC_RXD1
IO27	12	I/O	GPIO27, ADC2_CH7, TOUCH7, RTC_GPIO17, EMAC_RX_DV
IO14	13	I/O	GPIO14, ADC2_CH6, TOUCH6, RTC_GPIO16, MTMS, HSPICLK, HS2_CLK, SD_CLK, EMAC_TXD2
IO12	14	I/O	GPIO12, ADC2_CH5, TOUCH5, RTC_GPIO15, MTDI, HSPIQ, HS2_DATA2, SD_DATA2, EMAC_TXD3
GND	15	P	Ground
IO13	16	I/O	GPIO13, ADC2_CH4, TOUCH4, RTC_GPIO14, MTCK, HSPID, HS2_DATA3, SD_DATA3, EMAC_RX_ER
SHD/SD2*	17	I/O	GPIO9, SD_DATA2, SPIHD, HS1_DATA2, U1RXD
SWP/SD3*	18	I/O	GPIO10, SD_DATA3, SPIWP, HS1_DATA3, U1TXD
SCS/CMD*	19	I/O	GPIO11, SD_CMD, SPICS0, HS1_CMD, U1RTS
SCK/CLK*	20	I/O	GPIO6, SD_CLK, SPICLK, HS1_CLK, U1CTS
SDO/SD0*	21	I/O	GPIO7, SD_DATA0, SPIQ, HS1_DATA0, U2RTS
SDI/SD1*	22	I/O	GPIO8, SD_DATA1, SPID, HS1_DATA1, U2CTS
IO15	23	I/O	GPIO15, ADC2_CH3, TOUCH3, MTDO, HSPICS0, RTC_GPIO13, HS2_CMD, SD_CMD, EMAC_RXD3
IO2	24	I/O	GPIO2, ADC2_CH2, TOUCH2, RTC_GPIO12, HSPIWP, HS2_DATA0, SD_DATA0
IO0	25	I/O	GPIO0, ADC2_CH1, TOUCH1, RTC_GPIO11, CLK_OUT1, EMAC_TX_CLK
IO4	26	I/O	GPIO4, ADC2_CH0, TOUCH0, RTC_GPIO10, HSPIHD, HS2_DATA1, SD_DATA1, EMAC_TX_ER
IO16	27	I/O	GPIO16, HS1_DATA4, U2RXD, EMAC_CLK_OUT
IO17	28	I/O	GPIO17, HS1_DATA5, U2TXD, EMAC_CLK_OUT_180
IO5	29	I/O	GPIO5, VSPICS0, HS1_DATA6, EMAC_RX_CLK
IO18	30	I/O	GPIO18, VSPICLK, HS1_DATA7
IO19	31	I/O	GPIO19, VSPIQ, U0CTS, EMAC_TXD0

Name	No.	Type	Function
NC	32	-	-
IO21	33	I/O	GPIO21, VSPIHD, EMAC_TX_EN
RXD0	34	I/O	GPIO3, U0RXD, CLK_OUT2
TXD0	35	I/O	GPIO1, U0TXD, CLK_OUT3, EMAC_RXD2
IO22	36	I/O	GPIO22, VSPIWP, U0RTS, EMAC_TXD1
IO23	37	I/O	GPIO23, VSPID, HS1_STROBE
GND	38	P	Ground
GND	39	P	Ground

Note:

* Pins SCK/CLK, SDO/SD0, SDI/SD1, SHD/SD2, SWP/SD3 and SCS/CMD, namely, GPIO6 to GPIO11 are connected to the integrated SPI flash integrated on ESP-WROOM-32 and are not recommended for other uses.

2.3 Strapping Pins

ESP32-D0WDQ6 has five strapping pins. Software can read the value of these five bits from the register "GPIO_STRAPPING". During the chip power-on reset, the latches of the strapping pins sample the voltage level as strapping bits of "0" or "1", and hold these bits until the chip is powered down or shut down.

Each strapping pin is connected with its internal pull-up/pull-down during the chip reset. Consequently, if a strapping pin is unconnected or the connected external circuit is high-impedance, the internal weak pull-up/pull-down will determine the default input level of the strapping pins.

To change the strapping bit values, users can apply the external pull-down/pull-up resistances, or apply the host MCU's GPIOs to control the voltage level of these pins when powering ESP32 on.

After reset, the strapping pins work as the normal functions pins.

Refer to Table 4 for detailed boot modes of configuration by strapping pins.

Table 4: Strapping Pins

Voltage of Internal LDO (VDD_SDIO)					
Pin	Default	3.3V		1.8V	
MTDI	Pull-down	0		1	
Bootling Mode					
Pin	Default	SPI Flash Boot		Download Boot	
GPIO0	Pull-up	1		0	
GPIO2	Pull-down	Don't-care		0	
Debugging Log on U0TXD During Bootling					
Pin	Default	U0TXD Toggling		U0TXD Silent	
MTDO	Pull-up	1		0	
Timing of SDIO Slave					
Pin	Default	Falling-edge Input	Falling-edge Input	Rising-edge Input	Rising-edge Input
		Falling-edge Output	Rising-edge Output	Falling-edge Output	Rising-edge Output
MTDO	Pull-up	0	0	1	1
GPIO5	Pull-up	0	1	0	1

Note:

Firmware can configure register bits to change the settings of "Voltage of Internal LDO (VDD_SDIO)" and "Timing of SDIO Slave" after booting.

3. Functional Description

This chapter describes the modules and functions integrated in ESP-WROOM-32.

3.1 CPU and Internal Memory

ESP32-D0WDQ6 contains two low-power Xtensa® 32-bit LX6 microprocessors. The internal memory includes:

- 448 KB of ROM for booting and core functions.
- 520 KB of on-chip SRAM for data and instruction.
- 8 KB of SRAM in RTC, which is called RTC SLOW Memory and can be accessed by the co-processor during the Deep-sleep mode.
- 8 KB of SRAM in RTC, which is called RTC FAST Memory and can be used for data storage; it is accessed by the main CPU during RTC Boot from the Deep-sleep mode.
- 1 kbit of eFuse, of which 256 bits are used for the system (MAC address and chip configuration) and the remaining 768 bits are reserved for customer applications, including Flash-Encryption and Chip-ID.

3.2 External Flash and SRAM

ESP32-D0WDQ6 supports up to four 16-MB external QSPI flash and SRAM with hardware encryption based on AES to protect developer's programs and data.

ESP32 can access the external QSPI flash and SRAM through high-speed caches.

- Up to 16 MB of external flash are memory-mapped onto the CPU code space, supporting 8, 16 and 32-bit access. Code execution is supported.
- Up to 8 MB of external flash/SRAM are memory-mapped onto the CPU data space, supporting 8, 16 and 32-bit access. Data-read is supported on the flash and SRAM. Data-write is supported on the SRAM.

ESP-WROOM-32 integrates 4 MB of external SPI flash. The 4-MB SPI flash can be memory-mapped onto the CPU code space, supporting 8, 16 and 32-bit access. Code execution is supported. The integrated SPI flash is connected to GPIO6, GPIO7, GPIO8, GPIO9, GPIO10 and GPIO11. These six pins cannot be used as regular GPIO.

3.3 Crystal Oscillators

The frequencies of the main crystal oscillator supported include 40 MHz, 26 MHz and 24 MHz. The accuracy of crystal oscillators applied should be ± 10 PPM, and the operating temperature ranges from -40°C to 85°C .

When using the downloading tools, remember to select the right crystal oscillator type. In circuit design, capacitors C1 and C2 that connect to the earth are added to the input and output terminals of the crystal oscillator, respectively. The values of the two capacitors can be flexible, ranging from 6 pF to 22 pF. However, the specific capacitive values of C1 and C2 depend on further tests and adjustments of the overall performance of the whole circuit. Normally, the capacitive values of C1 and C2 are within 10 pF when the crystal oscillator frequency is 26 MHz, or $10\text{ pF} < \text{C1 and C2} < 22\text{ pF}$ when the crystal oscillator frequency is 40 MHz.

The frequency of the RTC crystal oscillator is typically 32 kHz or 32.768 kHz. The accuracy can be out of the range of ± 20 PPM, when the internal calibration is applied to correct the frequency offset. When the chip operates in low-power modes, the application chooses the external low-speed (32 kHz) crystal clock, rather than the internal RC oscillators, to achieve the accurate wakeup time.

3.4 Power Consumption

With the advanced power management technology, ESP32-D0WDQ6 can switch between different power modes as follows:

- Power mode
 - Active mode: chip radio is powered on. The chip can receive, transmit, or listen.
 - Modem-sleep mode: the CPU is operational and the clock is configurable. Wi-Fi / Bluetooth baseband and radio are disabled.
 - Light-sleep mode: the CPU is paused. The RTC and ULP-coprocessor are running. Any wake-up events (MAC, host, RTC timer, or external interrupts) will wake up the chip.
 - Deep-sleep mode: Only RTC is powered on. Wi-Fi and Bluetooth connection data are stored in RTC memory. The ULP-coprocessor can work.
 - Hibernation mode: The internal 8MHz oscillator and ULP-coprocessor are disabled. The RTC recovery memory is powered down. Only one RTC timer on the slow clock and some RTC GPIOs are active. The RTC timer or the RTC GPIOs can wake up the chip from the Hibernation mode.
- Sleep Pattern
 - Association sleep pattern: The power mode switches between the active mode and Modem-sleep/Light-sleep mode during this sleep pattern. The CPU, Wi-Fi, Bluetooth, and radio wake up at pre-determined intervals to keep Wi-Fi / BT connections on.
 - ULP sensor-monitored pattern: The main CPU is in the Deep-sleep mode. The ULP co-processor does sensor measurements and wakes up the main system, based on the measured data from sensors.

The power consumption varies with different power modes/sleep patterns, and work status, of functional modules (see Table 5).

Table 5: Power Consumption by Power Modes

Power mode	Comment	Power consumption
Active mode (RF working)	Wi-Fi Tx packet 13 dBm ~ 21 dBm	160 ~ 260 mA
	Wi-Fi / BT Tx packet 0 dBm	120 mA
	Wi-Fi / BT Rx and listening	80 ~ 90 mA
	Association sleep pattern (by Light-sleep)	0.9 mA@DTIM3, 1.2 mA@DTIM1
Modem-sleep mode	The CPU is powered on.	Max speed: 20 mA
		Normal: 5 ~ 10 mA
		Slow speed: 3 mA
Light-sleep mode	-	0.8 mA

Power mode	Comment	Power consumption
Deep-sleep mode	The ULP-coprocessor is powered on.	0.15 mA
	ULP sensor-monitored pattern	25 μ A @1% duty
	RTC timer + RTC memories	20 μ A
Hibernation mode	RTC timer only	5 μ A

3.5 Peripherals and Sensors

3.5.1 Peripherals and Sensors Description

Table 6: Peripherals and Sensors Description

Interface	Signal	Pin	Function
ADC	ADC1_CH0	SENSOR_VP	Two 12-bit SAR ADCs
	ADC1_CH3	SENSOR_VN	
	ADC1_CH4	IO32	
	ADC1_CH5	IO33	
	ADC1_CH6	IO34	
	ADC1_CH7	IO35	
	ADC2_CH0	IO4	
	ADC2_CH1	IO0	
	ADC2_CH2	IO2	
	ADC2_CH3	IO15	
	ADC2_CH4	IO13	
	ADC2_CH5	IO12	
	ADC2_CH6	IO14	
	ADC2_CH7	IO27	
	ADC2_CH8	IO25	
ADC2_CH9	IO26		
Ultra Low Noise Analog Pre-Amplifier	SENSOR_VP	IO36	Provides about 60dB gain by using larger capacitors on PCB
	SENSOR_VN	IO39	
DAC	DAC_1	IO25	Two 8-bit DACs
	DAC_2	IO26	
Touch Sensor	TOUCH0	IO4	Capacitive touch sensors
	TOUCH1	IO0	
	TOUCH2	IO2	
	TOUCH3	IO15	
	TOUCH4	IO13	
	TOUCH5	IO12	
	TOUCH6	IO14	
	TOUCH7	IO27	
	TOUCH8	IO33	
TOUCH9	IO32		

Interface	Signal	Pin	Function
SD / SDIO / MMC Host Controller	HS2_CLK	MTMS	Supports SD memory card V3.01 standard
	HS2_CMD	MTDO	
	HS2_DATA0	IO2	
	HS2_DATA1	IO4	
	HS2_DATA2	MTDI	
	HS2_DATA3	MTCK	
Motor PWM	PWM0_OUT0~2	Any GPIOs*	Three channels of 16-bit timers generate PWM waveforms; each has a pair of output signals. Three fault detection signals. Three event capture signals. Three sync signals.
	PWM1_OUT_IN0~2		
	PWM0_FLT_IN0~2		
	PWM1_FLT_IN0~2		
	PWM0_CAP_IN0~2		
	PWM1_CAP_IN0~2		
	PWM0_SYNC_IN0~2		
	PWM1_SYNC_IN0~2		
LED PWM	ledc_hs_sig_out0~7	Any GPIOs*	16 independent channels @80MHz clock/RTC CLK. Duty accuracy: 16 bits.
	ledc_ls_sig_out0~7		
UART	U0RXD_in	Any GPIOs*	Two UART devices with hardware flow-control and DMA
	U0CTS_in		
	U0DSR_in		
	U0TXD_out		
	U0RTS_out		
	U0DTR_out		
	U1RXD_in		
	U1CTS_in		
	U1TXD_out		
	U1RTS_out		
	U2RXD_in		
	U2CTS_in		
	U2TXD_out		
	U2RTS_out		
I2C	I2CEXT0_SCL_in	Any GPIOs*	Two I2C devices in slave or master modes
	I2CEXT0_SDA_in		
	I2CEXT1_SCL_in		
	I2CEXT1_SDA_in		
	I2CEXT0_SCL_out		
	I2CEXT0_SDA_out		
	I2CEXT1_SCL_out		
	I2CEXT1_SDA_out		

Interface	Signal	Pin	Function
I2S	I2S0I_DATA_in0~15	Any GPIOs*	Stereo input and output from/to the audio codec, and parallel LCD data output
	I2S0O_BCK_in		
	I2S0O_WS_in		
	I2S0I_BCK_in		
	I2S0I_WS_in		
	I2S0I_H_SYNC		
	I2S0I_V_SYNC		
	I2S0I_H_ENABLE		
	I2S0O_BCK_out		
	I2S0O_WS_out		
	I2S0I_BCK_out		
	I2S0I_WS_out		
	I2S0O_DATA_out0~23		
	I2S1I_DATA_in0~15		
	I2S1O_BCK_in		
	I2S1O_WS_in		
	I2S1I_BCK_in		
	I2S1I_WS_in		
	I2S1I_H_SYNC		
	I2S1I_V_SYNC		
	I2S1I_H_ENABLE		
	I2S1O_BCK_out		
	I2S1O_WS_out		
I2S1I_BCK_out			
I2S1I_WS_out			
I2S1O_DATA_out0~23			
Remote Controller	RMT_SIG_IN0~7	Any GPIOs*	Eight channels of IR transmitter and receiver for various waveforms
	RMT_SIG_OUT0~7		

Interface	Signal	Pin	Function
Parallel QSPI	SPIHD	SHD/SD2	Supports Standard SPI, Dual SPI, and Quad SPI that can be connected to the external flash and SRAM
	SPIWP	SWP/SD3	
	SPICS0	SCS/CMD	
	SPICLK	SCK/CLK	
	SPIQ	SDO/SD0	
	SPID	SDI/SD1	
	HSPICLK	IO14	
	HSPICS0	IO15	
	HSPIQ	IO12	
	HSPID	IO13	
	HSPIHD	IO4	
	HSPIWP	IO2	
	VSPICLK	IO18	
	VSPICS0	IO5	
	VSPIQ	IO19	
	VSPID	IO23	
VSPIHD	IO21		
VSPIWP	IO22		
General Purpose SPI	HSPIQ_in/_out	Any GPIOs*	Standard SPI consists of clock, chip-select, MOSI and MISO. These SPIs can be connected to LCD and other external devices. They support the following features: <ul style="list-style-type: none"> • both master and slave modes; • 4 sub-modes of the SPI format transfer that depend on the clock phase (CPHA) and clock polarity (CPOL) control; • CLK frequencies by a divider; • up to 64 bytes of FIFO and DMA.
	HSPIQ_in/_out		
	HSPIQ_in/_out		
	HSPIQ_in/_out		
	HSPIQ_in/_out		
	HSPIQ_in/_out		
	HSPIQ_in/_out		
	HSPIQ_in/_out		
	HSPIQ_in/_out		
	HSPIQ_in/_out		
	HSPIQ_in/_out		
JTAG	MTDI	IO12	JTAG for software debugging
	MTCK	IO13	
	MTMS	IO14	
	MTDO	IO15	

Interface	Signal	Pin	Function
SDIO Slave	SD_CLK	IO6	SDIO interface that conforms to the industry standard SDIO 2.0 card specification. On ESP-WROOM-32 these pins are connected to the integrated SPI flash.
	SD_CMD	IO11	
	SD_DATA0	IO7	
	SD_DATA1	IO8	
	SD_DATA2	IO9	
	SD_DATA3	IO10	
EMAC	EMAC_TX_CLK	IO0	Ethernet MAC with MII/RMII interface
	EMAC_RX_CLK	IO5	
	EMAC_TX_EN	IO21	
	EMAC_TXD0	IO19	
	EMAC_TXD1	IO22	
	EMAC_TXD2	IO14	
	EMAC_TXD3	IO12	
	EMAC_RX_ER	IO13	
	EMAC_RX_DV	IO27	
	EMAC_RXD0	IO25	
	EMAC_RXD1	IO26	
	EMAC_RXD2	TXD	
	EMAC_RXD3	IO15	
	EMAC_CLK_OUT	IO16	
	EMAC_CLK_OUT_180	IO17	
	EMAC_TX_ER	IO4	
	EMAC_MDC_out	Any GPIOs*	
	EMAC_MDI_in	Any GPIOs*	
	EMAC_MDO_out	Any GPIOs*	
EMAC_CRS_out	Any GPIOs*		
EMAC_COL_out	Any GPIOs*		

Note:

- Functions of Motor PWM, LED PWM, UART, I2C, I2S, general purpose SPI and Remote Controller can be configured to any GPIO except GPIO6, GPIO7, GPIO8, GPIO9, GPIO10 and GPIO11.
- In Table 6, for the items marked with "Any GPIOs*" in the "Pin" column, users should note that GPIO6, GPIO7, GPIO8, GPIO9, GPIO10 and GPIO11 are connected to the integrated SPI flash of ESP-WROOM-32 and are not recommended for other uses.

3.5.2 Peripheral Schematics

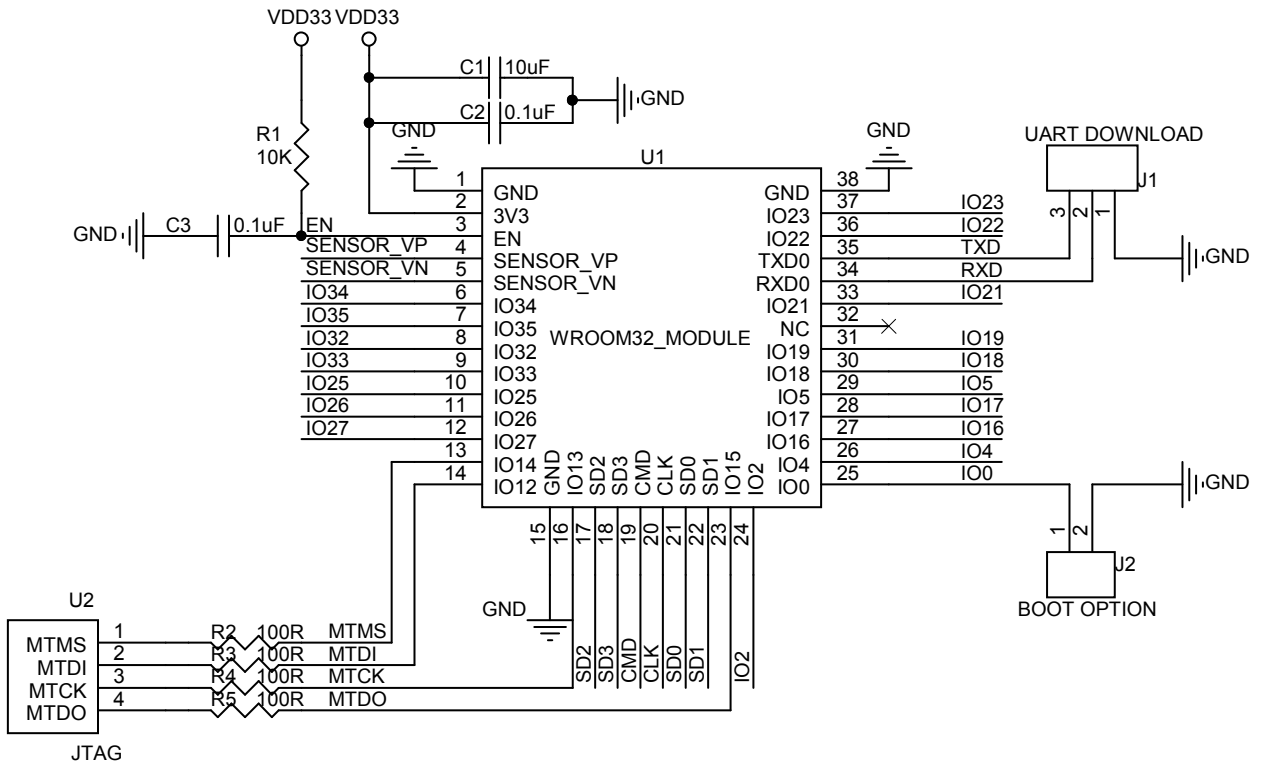

Figure 2: ESP-WROOM-32 Peripheral Schematics

Note:

The MTDI should be kept at low electric level.

4. Electrical Characteristics

Note:

The specifications in this chapter have been tested under the following general condition: $V_{BAT} = 3.3V$, $T_A = 27^{\circ}C$, unless otherwise specified.

4.1 Absolute Maximum Ratings

Table 7: Absolute Maximum Ratings

Rating	Condition	Value	Unit
Storage temperature	-	-40 ~ 85	°C
Maximum soldering temperature	-	260	°C
Supply voltage	IPC/JEDEC J-STD-020	+2.2 ~ +3.6	V

4.2 Recommended Operating Conditions

Table 8: Recommended Operating Conditions

Operating condition	Symbol	Min	Typ	Max	Unit
Operating temperature	-	-40	20	85	°C
Supply voltage	VDD	2.2	3.3	3.6	V
Operating current	I_{VDD}	0.5	-	-	A

4.3 Digital Terminal Characteristics

Table 9: Digital Terminal Characteristics

Terminals	Symbol	Min	Typ	Max	Unit
Input logic level low	V_{IL}	-0.3	-	0.25VDD	V
Input logic level high	V_{IH}	0.75VDD	-	VDD+0.3	V
Output logic level low	V_{OL}	N	-	0.1VDD	V
Output logic level high	V_{OH}	0.8VDD	-	N	V

4.4 Wi-Fi Radio

Table 10: Wi-Fi Radio Characteristics

Description	Min	Typ	Max	Unit
General Characteristics				
Input frequency	2412	-	2484	MHz
Input impedance	-	50	-	Ω
Input reflection	-	-	-10	dB
Output power of PA	15.5	19.5	21.5	dBm
Sensitivity				

DSSS, 1 Mbps	-	-98	-	dBm
CCK, 11 Mbps	-	-90	-	dBm
OFDM, 6 Mbps	-	-93	-	dBm
OFDM, 54 Mbps	-	-75	-	dBm
HT20, MCS0	-	-93	-	dBm
HT20, MCS7	-	-73	-	dBm
HT40, MCS0	-	-90	-	dBm
HT40, MCS7	-	-70	-	dBm
MCS32	-	-91	-	dBm
Adjacent Channel Rejection				
OFDM, 6 Mbps	-	37	-	dB
OFDM, 54 Mbps	-	21	-	dB
HT20, MCS0	-	37	-	dB
HT20, MCS7	-	20	-	dB

4.5 Bluetooth LE Radio

4.5.1 Receiver

Table 11: Receiver Characteristics - BLE

Parameter	Conditions	Min	Typ	Max	Unit
Sensitivity @0.1% BER	-	-	-98	-	dBm
Maximum received signal @0.1% BER	-	0	-	-	dBm
Co-channel C/I	-	-	+10	-	dB
Adjacent channel selectivity C/I	F = F0 + 1 MHz	-	-5	-	dB
	F = F0 - 1 MHz	-	-5	-	dB
	F = F0 + 2 MHz	-	-25	-	dB
	F = F0 - 2 MHz	-	-35	-	dB
	F = F0 + 3 MHz	-	-25	-	dB
	F = F0 - 3 MHz	-	-45	-	dB
Out-of-band blocking performance	30 MHz - 2000 MHz	-10	-	-	dBm
	2000 MHz - 2400 MHz	-27	-	-	dBm
	2500 MHz - 3000 MHz	-27	-	-	dBm
	3000 MHz - 12.5 GHz	-10	-	-	dBm
Intermodulation	-	-36	-	-	dBm

4.5.2 Transmit

Table 12: Transmit Characteristics - BLE

Parameter	Conditions	Min	Typ	Max	Unit
RF transmit power	-	-	+7.5	+10	dBm
RF power control range	-	-	25	-	dB
	F = F0 + 1 MHz	-	-14.6	-	dBm
	F = F0 - 1 MHz	-	-12.7	-	dBm

Parameter	Conditions	Min	Typ	Max	Unit
	F = F0 + 2 MHz	-	-44.3	-	dBm
	F = F0 - 2 MHz	-	-38.7	-	dBm
	F = F0 + 3 MHz	-	-49.2	-	dBm
	F = F0 - 3 MHz	-	-44.7	-	dBm
	F = F0 + > 3 MHz	-	-50	-	dBm
	F = F0 - > 3 MHz	-	-50	-	dBm
$\Delta f1_{avg}$	-	-	-	265	kHz
$\Delta f2_{max}$	-	247	-	-	kHz
$\Delta f2_{avg}/\Delta f1_{avg}$	-	-	-0.92	-	-
ICFT	-	-	-10	-	kHz
Drift rate	-	-	0.7	-	kHz/50 μ s
Drift	-	-	2	-	kHz

4.6 Reflow Profile

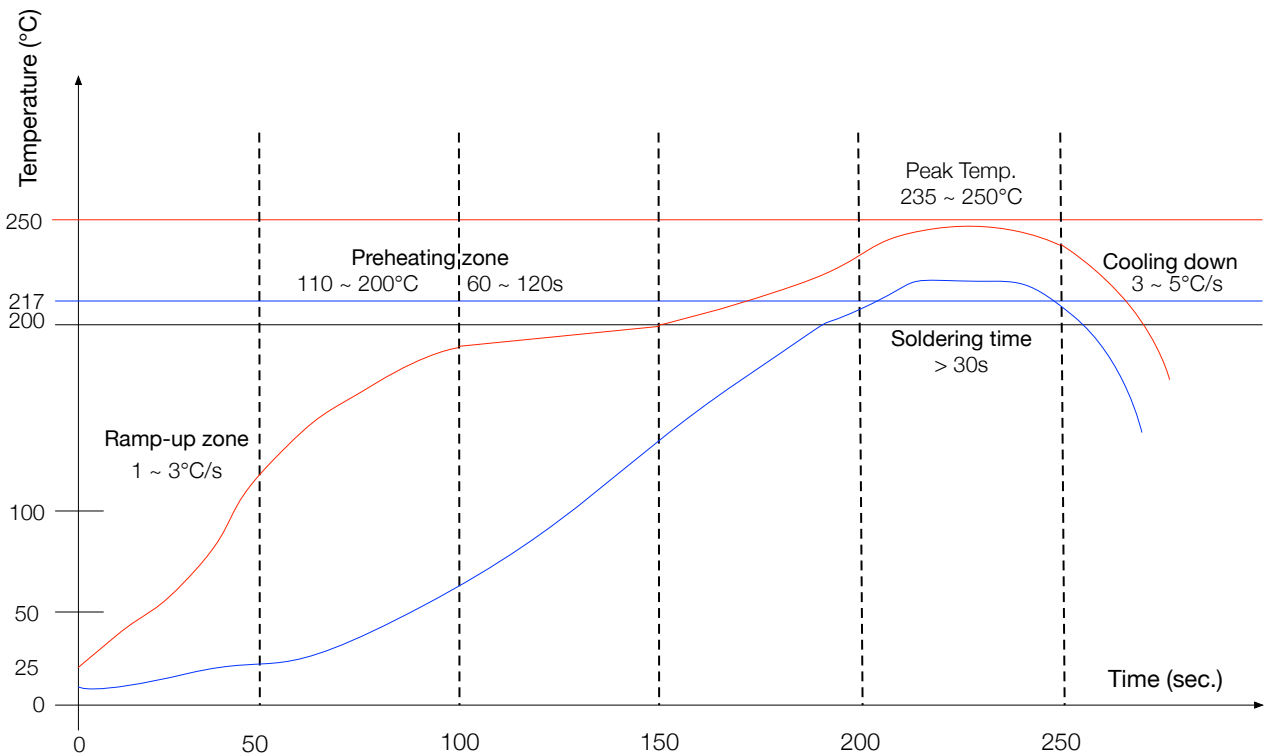

Ramp-up zone (升温区): Temp. <150°C, Time 60 ~ 90s, Ramp-up rate 1 ~ 3°C/s.

Preheating zone (预热恒温区): Temp. 150 ~ 200°C, Time 60 ~ 120s, Ramp-up rate 0.3 ~ 0.8°C/s.

Reflow soldering zone (回流焊接区): Peak Temp. 235 ~ 250°C (<245°C recommended), Time 30 ~ 70s.

Cooling down zone (冷却区): Temp. 217 ~ 170°C, Ramp-down rate 3 ~ 5°C/s.

Sn&Ag&Cu Lead-free solder (SAC305)/焊料为锡银铜合金无铅焊料

Figure 3: Reflow Profile

5. Schematics

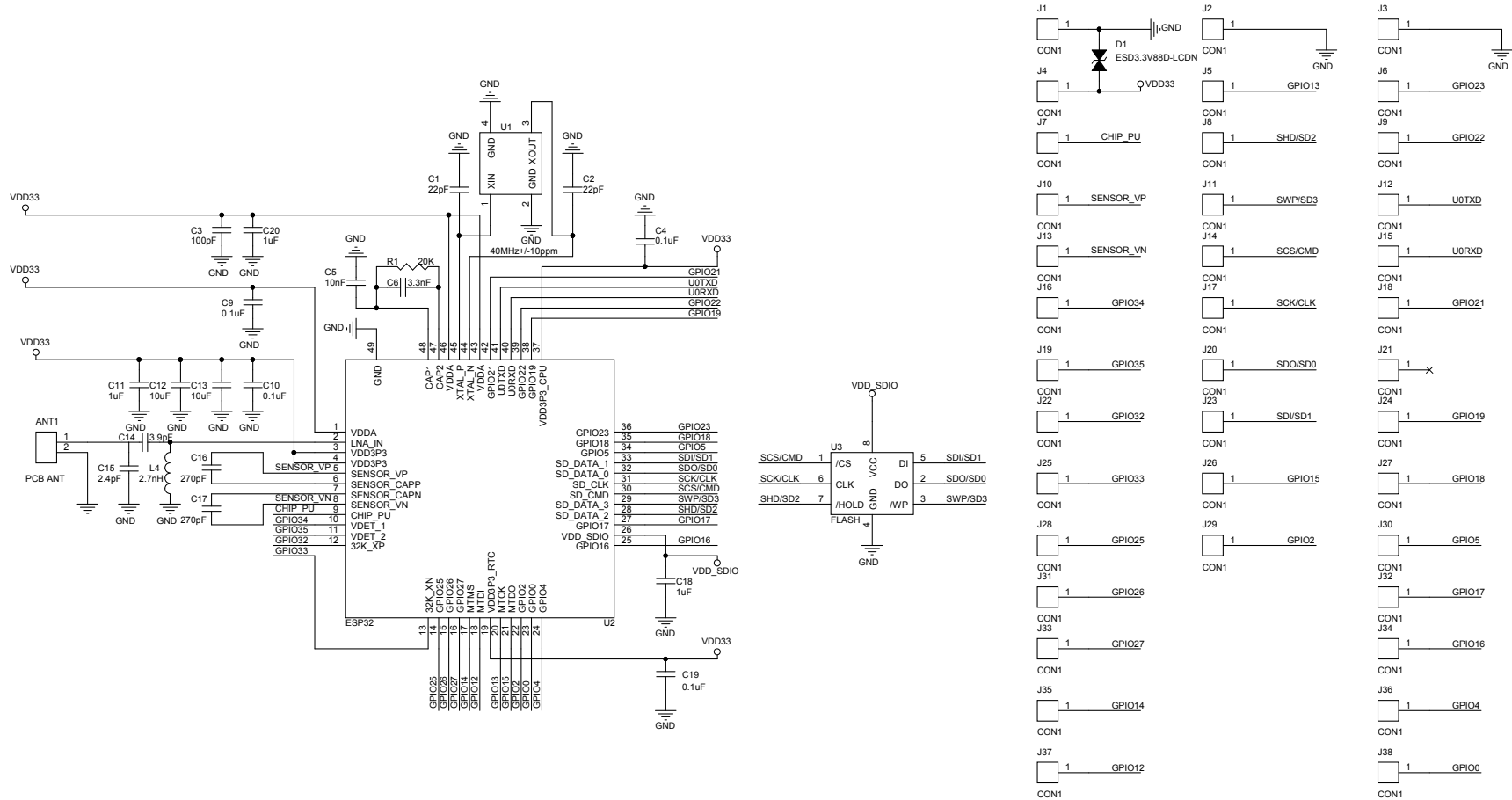

Figure 4: ESP-WROOM-32 Schematics

Note:

The capacitance of C1 and C2 varies with the selection of the crystal.

6. Learning Resources

6.1 Must-Read Documents

The following link provides related documents of ESP32.

- [ESP32 Datasheet](#)
This document provides introduction to the specifications of the ESP32 hardware, including overview, pin definitions, functional description, peripheral interface, electrical characteristics, etc.
- [ESP32 Technical Reference Manual](#)
The manual provides detailed information on how to use the ESP32 memory and peripherals.
- [ESP32 Hardware Resources](#)
The zip files include the schematics, PCB layout, Gerber and BOM list of ESP32-DevKitC.
- [ESP32 Pin List](#)
This list provides a quick reference guide of the IO MUX, Ethernet MAC, GPIO Matrix, and strapping pins of ESP32.
- [ESP32 Hardware Design Guidelines](#)
The guidelines outline recommended design practices when developing standalone or add-on systems based on the ESP32 series of products, including ESP32, the ESP-WROOM-32 module, and ESP32-DevKitC — the development board.
- [ESP32 AT Instruction Set and Examples](#)
This document introduces the ESP32 AT commands, explains how to use them and provides examples of several common AT commands.

6.2 Must-Have Resources

Here are the ESP32-related must-have resources.

- [ESP32 BBS](#)
This is an Engineer-to-Engineer (E2E) Community for ESP32 where you can post questions, share knowledge, explore ideas, and help solve problems with fellow engineers.
- [ESP32 Github](#)
ESP32 development projects are freely distributed under Espressif's MIT license on Github. It is established to help developers get started with ESP32 and foster innovation and the growth of general knowledge about the hardware and software surrounding ESP32 devices.
- [ESP32 Tools](#)
This is a web-page where users can download ESP32 Flash Download Tools and the zip file "ESP32 Certification and Test".
- [ESP32 IDF](#)
This web-page links users to the official IoT development framework for ESP32.
- [ESP32 Resources](#)
This webpage provides the links to all the available ESP32 documents, SDK and tools.